

Cast Iron Gas-Fired Water Boiler

Quality Engineered for Efficiency and Dependability

ODV-B Series



Olsen
Heating & Cooling Products

ODV-B Series

Gas-Fired/Natural or Propane, Hot Water

Warm-Up To The Versatility Of The ODV-B Boiler

The ODV-B series boiler combines high efficiency and venting flexibility with a compact design that allows installation in virtually any residential application. With quality components such as cast-iron heat exchangers and stainless steel burners, the ODV-B is an ideal choice for new or existing homes.

Venting and Installation Flexibility

The ODV-B Series boiler can be vented vertically up a chimney or horizontally through an exterior wall making it a convenient and cost effective choice for a variety of applications. Standing less than 31 inches high, this low profile boiler fits into areas that other boilers can not. The ODV-B is also an ideal choice when converting a home from electric heat to a hot water system.

Cast Iron Heat Exchanger

The ODV-B utilizes cast iron construction because of its durability and efficient heat transfer capabilities. Cast iron sections and push nipples are an integral part of each ODV-B heat exchanger. Using only the highest quality cast iron and heat transfer designs, the ODV-B will provide many years of efficient and trouble-free operation.

High Energy Efficiency and Lower Heating Costs

With efficiency ratings as high as 83%, the ODV-B provides increased energy savings resulting in lower fuel bills. With the potential cost savings this represents, the ODV-B boiler will pay for itself in a few short years.

83%
Efficiency Rating



Compare The Difference High Efficiency Makes

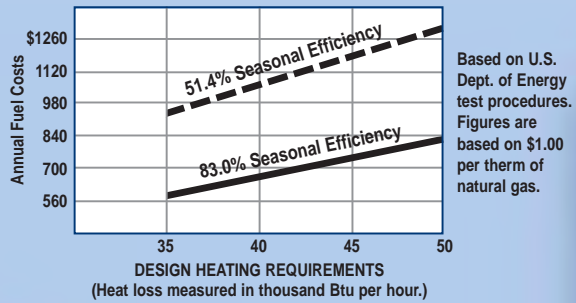

This graph illustrates the difference in annual operating costs between boilers with higher and lower efficiencies. Boilers installed ten or more years ago have seasonal efficiencies as low as 50%. So, your savings in fuel dollars with Olsen's ODV-B boiler can repay its installed cost in a few short years!

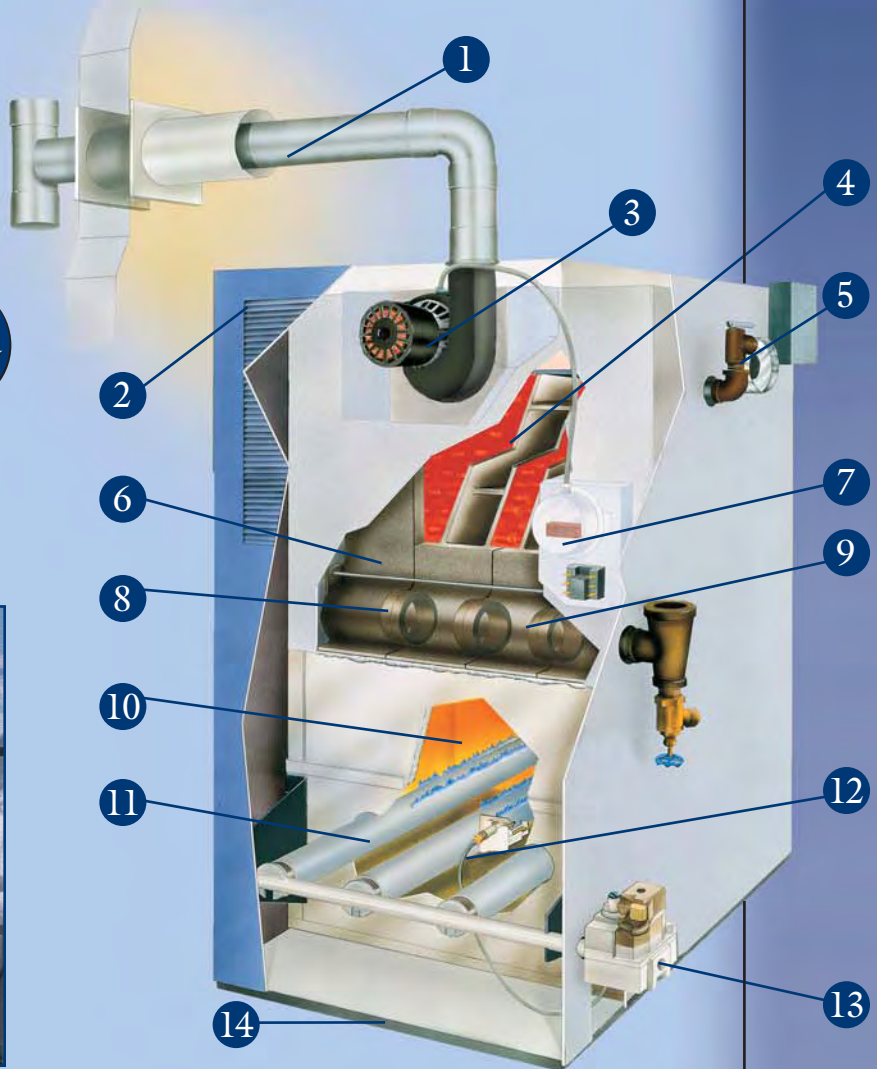

The ODV-B Boiler Details.

- 1 Specially Designed Rust-Proof Stainless Steel Vent Piping (Not Supplied)
- 2 Pre-Painted Steel Finish
- 3 UL-Approved® Safety-Tested Exhaust Fan
- 4 Computer Designed Heat Transfer Pin Configuration
- 5 Pressure Relief Valve
- 6 A.S.M.E.-Approved Cast Iron Sections (Limited Lifetime Warranty)
- 7 Positive Vent Safety Shut-Off
- 8 Cast Iron Push Nipples
- 9 Cast Iron Heat Exchanger
- 10 Whisper-Quiet Flame
- 11 Corrosion-Resistant Stainless Steel Burners
- 12 Reliable Electronic Pilot Ignition Sensor
- 13 Safety Redundant Gas Valve
- 14 Optional Combustible Floor Installation Kit

Built-In Safety Devices

The ODV-B is equipped with an automatic gas shut-off feature that assures the safety of all family members. A three-phase fuel safety system must sense proper flue pressure before it opens the main gas valve. This gas safety system also checks for proper component function before proceeding to the ignition mode.

Factory Tested, Pre-Wired & Packaged

The ODV-B boiler arrives ready to install. Prior to leaving the factory, it is subjected to nine quality assurance checks to ensure trouble-free start-up and performance. Should service be necessary, parts are readily available through our national wholesaler network.

Manufacturer's Limited Lifetime Warranty

ECR International backs its residential, cast iron heat exchangers with a Limited Lifetime Warranty. This warranty is meant to protect your investment, but it is also offered to illustrate our commitment to customer satisfaction and manufacturing pride. We believe this product is manufactured using the finest techniques and materials available.

Key ODV-B Boiler Features

- Venting Flexibility - Side Wall or Chimney
- Low Profile Compact Design
- Cast Iron Sections and Push Nipples
- Energy Efficiency Ratings as high as 83%
- Factory Tested, Pre-Wired and Packaged for Fast, Easy Installation
- Nine Quality Assurance Checks Ensure Trouble Free Start Up and Performance
- Limited Lifetime Warranty

ODV-B Series Cast Iron, Gas-Fired, Hot Water Boiler for chimney or through-the-wall venting

BOILER NO.	A.G.A. INPUT BTU/HR.	HEATING CAPACITY BTU/HR.	I=B=R NET OUTPUT BTU/HR.	NATURAL GAS INLET	DIMENSIONS						PUMP SIZE SUP. & RET. TAPPINGS	NO. OF BURNERS	AFUE RATINGS	SHIPPING WEIGHT (LBS.)
					A	B	C	D	E	F				
ODV-50B	50,000	42,000	37,000	1/2	11 1/4	2 3/8	3	30 3/4"	27	6 3/8	1 1/4"	1	83%	203
ODV-100B	100,000	82,000	71,000	1/2	15 5/8	4 1/8	3	30 3/4"	27	6 3/8	1 1/4"	2	82%	268
ODV-125B	125,000	103,000	90,000	1/2	19	6	3	30 3/4"	27	6 3/8	1 1/4"	3	82%	303
ODV-150B	150,000	122,000	106,000	1/2	19	6	4	30 3/4"	27	6 3/8	1 1/4"	3	80%	303
ODV-200B	200,000	160,000	139,000	3/4	22 7/8	8	4	30 3/4"	28	7	1 1/4"	4	80%	393

STANDARD EQUIPMENT: Boiler Jacket, Cast Iron Boiler, Combination Aquastat Relay, Combination Temperature/Pressure Gauge, Circulator, Main Gas Burners, Electronic Ignition System, A.S.M.E. Relief Valve, Drain Valve, Induced Draft Fan and Safety Pressure Switch.

OPTIONAL EQUIPMENT: B-vent adapter kits, combustible floor kit.

Dimensions

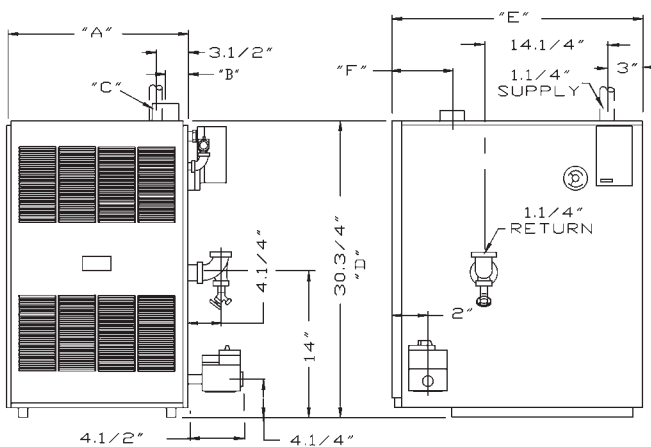

Category I (Chimney) Vertical Venting Installation Type B Vent

This diagram is for illustration of components only. Refer to installation manual for correct venting procedure.

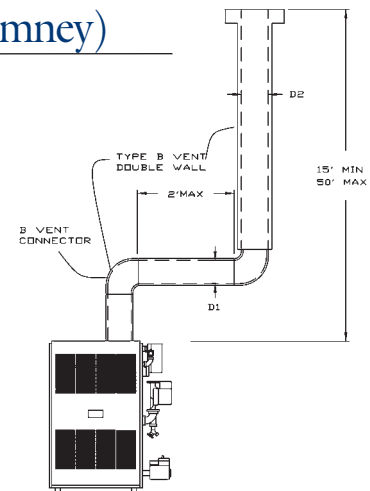

Explanation Notes

All boilers are design-certified for installation on non-combustible floors. For installation on combustible floors, use a combustible floor kit. This will increase dimension D approximately 1-13/16 inches.

This boiler is designed and certified as a Category I (chimney), or III (through-the-wall), appliance. A through-the-wall installation requires a special horizontal Category III venting system.

A vertical/chimney installation requires a correctly sized doublewall, type "B" vertical vent and vent connector.

Consult factory instructions, and the Can/CSA B-149.00-1 Natural Gas and Propane installation code, for required sizing of Category I fan-assisted appliances.

A masonry chimney installation requires a chimney liner.

Consult installation instructions for maximum vent lengths and proper configurations.

Specifications and dimensions are subject to change without notice.

Your Assurance Of Quality

All Olsen products are designed, tested, and assembled to ensure that you get the very best in home heating and cooling comfort and value. Each one meets or exceeds all recognized safety, performance and efficiency standards.

For more information on Olsen heating and cooling products contact Customer Service at (800) 325-5479



An ISO 9001-2008 Certified Company



2210 Dwyer Avenue, Utica NY 13504-4729
 Phone: (315) 797-1310 • Fax: (866) 432-7329
 e-mail: info@ecrinternational.com
 web site: www.ecrinternational.com