

95M-200 GAS-FIRED DIRECT VENT MODULATING HOT WATER BOILER

USER'S INFORMATION MANUAL

WARNING: If the information in this manual is not followed exactly, a fire or explosion may result causing property damage, personal injury or loss of life.

- Do not store or use gasoline or other flammable vapors and liquids in the vicinity of this or any other appliance.

- WHAT TO DO IF YOU SMELL GAS
 - Do not try to light any appliance.
 - Do not touch any electrical switch; do not use any phone in your building.
 - Immediately call your gas supplier from a neighbor's phone. Follow the gas supplier's instructions.
 - If you cannot reach your gas supplier, call the fire department.

- Installation and service must be performed by a qualified installer, service agency or the gas supplier.

General

This boiler has few user serviceable parts. Maintenance and Service must be completed by qualified agency.

 **WARNING**

Fire, explosion, asphyxiation and electrical shock hazard. Improper maintenance and service could result in death or serious injury. Read this manual and understand all requirements, including use of qualified agency where directed.

What To Do Should Overheating Occur

Do not turn off or disconnect electrical supply to boiler and pumps. Shut off gas supply at location external to appliance.

What To Do If Boiler Or Any Part Has Been Under Water

Do not use boiler if any part has been under water. Immediately call a qualified service technician to inspect boiler and to replace any part of control system and any gas control which has been under water.

Become familiar with symbols identifying potential hazards.

This is the safety alert symbol. Symbol alerts you to potential personal injury hazards. Obey all safety messages following this symbol to avoid possible injury or death.

 **DANGER**

Indicates a hazardous situation which, if not avoided, WILL result in death or serious injury

 **WARNING**

Indicates a hazardous situation which, if not avoided, could result in death or serious injury.

 **CAUTION**

Indicates a hazardous situation which, if not avoided, could result in minor or moderate injury.

NOTICE

Used to address practices not related to personal injury.

⚠ WARNING

If you do not follow these instructions exactly, a fire or explosion may result causing property damage, personal injury or loss of life.

- This appliance is equipped with an ignition device which automatically lights burner. **Do NOT try to light this burner by hand.**
- Before operating smell all around appliance area for gas. Be sure to smell next to floor because some gas is heavier than air and will settle to the floor.
- **Use only your hand to turn the gas shutoff valve.** Never use tools. If valve will not turn by hand, do not try to repair it, call a qualified service technician. Force or attempted repair may result in fire or explosion.
- **Do not use this appliance if any part has been under water.** Immediately call a qualified service technician to inspect appliance and to replace any part of control system and any gas control which has been under water.

⚠ CAUTION

WHAT TO DO IF YOU SMELL GAS

- Do not try to light any appliance.
- Do not touch any electrical switch; do not use any phone in your building.
- Immediately call your gas supplier from a neighbor's phone. Follow the gas supplier's instructions.
- If you cannot reach your gas supplier, call the fire department.

Operating Instructions

Stop! Read Safety information above.

1. Set thermostat to lowest setting.
2. Turn "OFF" all electrical power to appliance.
3. This appliance is equipped with an ignition device which automatically lights the burner. **Do not try to light burner by hand!**
4. Remove front jacket panel.
5. Turn gas shutoff valve clockwise ↻ to closed position. Handle should be perpendicular to gas pipe. See Figures 1 and 2.
6. Wait 5 minutes for any gas to clear. Smell for gas, including near floor. If you smell gas, **STOP!** Follow instructions on this page: "**What To Do If You Smell Gas.**" If you do **not** smell gas, go to next step.
7. Turn gas shutoff valve counter clockwise ↻ to the open position. Handle should be parallel to gas pipe.
8. Replace front jacket panel.
9. Turn "ON" electrical power to appliance.
10. Set thermostat to desired setting.

If the appliance will not operate, follow instructions TO TURN OFF GAS TO APPLIANCE and call your service technician or gas supplier.

To Turn Off Gas To Appliance

1. Set thermostat to lowest setting.
2. Turn "OFF" all electric power to appliance if service is to be performed.
3. Remove front jacket panel.
4. Turn gas shutoff valve handle clockwise ↻ to closed position. Handle should be perpendicular to gas pipe. See Figure 1. Replace front jacket panel.

Figure 1 - Gas Shutoff Valve

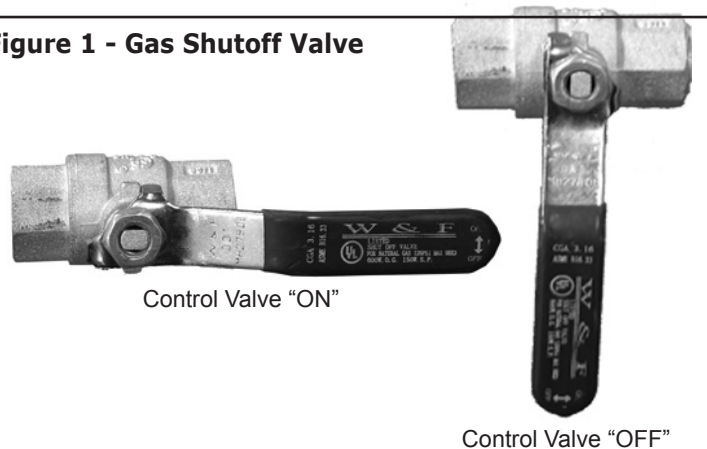
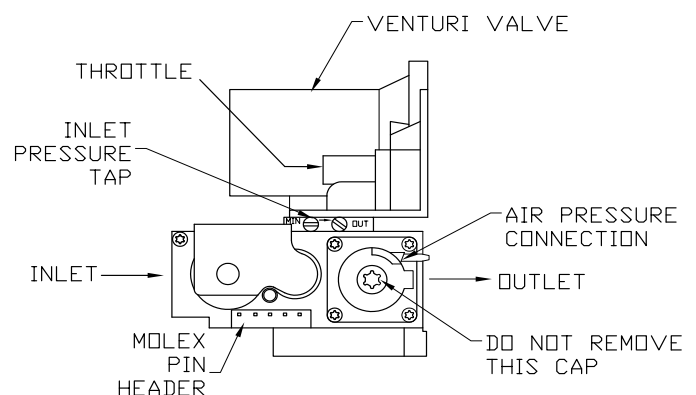

Figure 2 - Gas Shutoff Valve



Blocked Flue/Vent Safety Shutoff

Blocked Flue/Vent Safety Shutoff shuts off main burner gas in event flow of combustion products through flue ways is reduced.

In event of blocked flue ways, enough air will not be available to support combustion, boiler control will lockout due to loss of proper air flow. If the boiler can not be restored to normal operating condition by resetting control, contact qualified service agency to check the flue ways and vent pipe for blockage.

Maintenance and Cleaning

Regular service and maintenance by qualified service agency must be performed at least once every 12 months preferably at start of each heating season to assure safe, trouble free operation and maximum efficiency. Boiler owner SHOULD NOT attempt these procedures.

This annual service should include at a minimum:

- Examine flue passages between boiler sections, burner, and condensate lines, and clean if necessary.
- Inspect venting and air intake system and clean if necessary.
- Place boiler in operation and perform checkout procedure.
- Inspect condensate drain pipe and clean if necessary.
- Check all gasketed and threaded joints for leaks, and repair if necessary.

Particular attention should be given to potential deterioration from corrosion or other sources. Detailed procedures can be found in Section XII, Maintenance and Cleaning, of Installation, Operation and Maintenance Manual.

Boiler owner SHOULD perform the following periodic maintenance procedures.

Daily During Heating Season

1. Check for and remove any obstruction to flow of combustion air or venting of flue gases.
2. Check boiler area is free from combustible materials, gasoline, and other flammable vapors and liquids.

Monthly During Heating Season:

1. Remove jacket front and top panels and check for piping leaks around relief valve and other fittings. If found, contact qualified service agency. DO NOT USE STOP LEAK COMPOUNDS.
2. Test relief valve. Refer to valve manufacturers instructions packaged with relief valve.
3. Visually inspect venting and air intake system for proper operation. If vent or air intake show any signs of deterioration or leakage, contact qualified service agency to repair or replace them immediately and to insure proper reassembly and resealing of the system.
4. Visually inspect PVC condensate drain pipe for proper operation. If drain pipe shows any signs of blockage, leakage, or deterioration contact qualified service agency to clean, repair, or replace it immediately.
5. Check air vent(s) for leakage.
6. Where low water cut offs are used, periodic inspection of low water cut off is necessary, including flushing of float type devices. Refer to low water cut off manufacturer's specific instructions.

End of Each Heating Season (Annual Shut Down Procedure)

1. Turn off gas to boiler as described To Turn Off Gas To Appliance on page 3.
2. If heating system is to remain out of service during freezing weather and does not contain antifreeze, drain system completely. If boiler will be exposed to freezing temperatures, drain condensate lines. Otherwise, do not drain the system or boiler.

NOTICE

Should overheating occur or gas supply fail to shut off, do not turn off or disconnect electrical supply to the pump. Do shut off the gas supply at location external to the appliance.