

# 95M-200 GAS-FIRED DIRECT VENT MODULATING HOT WATER BOILER

## **WARNING**

If the information in this manual is not followed exactly, a fire or explosion may result, causing property damage, personal injury, or loss of life.

Do not store or use gasoline or other flammable vapors and liquids in the vicinity of this or any other appliance.

### WHAT TO DO IF YOU SMELL GAS

- Do not try to light any appliance.
- Do not touch any electrical switch; do not use any phone in your building.
- Immediately call your gas supplier from a neighbor's phone. Follow the gas supplier's instructions. If you cannot reach your gas supplier, call the fire department.

Installation and service must be performed by a qualified installer, service agency, or the gas supplier.



## I - FOR YOUR SAFETY

*Do not store or use gasoline or other flammable vapors and liquids in the vicinity of this or any other appliance.*



If the information in this manual is not followed exactly, a fire or explosion may result, causing property damage, personal injury, or loss of life.

A. This appliance does not have a pilot. It is equipped with an ignition device which automatically lights the burner. Do not try to light the burner by hand.

B. BEFORE OPERATING smell all around the appliance area for gas. Be sure to smell next to the floor because some gas is heavier than air and will settle on the floor.

### **WHAT TO DO IF YOU SMELL GAS**

- Do not try to light any appliance.
- Do not touch any electrical switch; do not use any phone in your building.
- Immediately call your gas supplier from a neighbor's phone. Follow the gas supplier's instructions. If you cannot reach your gas supplier, call the fire department.

C. Use only your hand to push in or turn the gas control knob. Never use tools. If the knob will not turn by hand, don't try to repair it. Call a qualified service technician. Force or attempted repair may result in a fire or explosion.

D. Do not use this appliance if any part has been under water. Immediately call a qualified service technician to inspect the appliance and to replace any part of the control system and any gas control which has been under water.

## II - OPERATING INSTRUCTIONS

1. STOP! Read the safety information above in this manual.
2. Set the thermostat to the lowest setting.
3. Turn off all electric power to the appliance.
4. This appliance is equipped with an ignition device which automatically lights the burner. DO NOT TRY TO LIGHT THE BURNER BY HAND.
5. Remove the front jacket panel.
6. Turn the gas control valve clockwise ↻ to "OFF". The handle of the valve should be perpendicular to the pipe in the "OFF" position.



Control Valve "ON"



Control Valve "OFF"

7. Wait five (5) minutes to clear out any gas. Then smell for gas, including near the floor. If you smell gas, STOP! Follow "B" in the safety information above in this manual. If you don't smell gas, go to the next step.
8. Turn the gas control valve counterclockwise ↺ to the "ON" position. The handle of the valve should be parallel to the pipe in the "ON" position.
9. Replace the front jacket panel.
10. Set the thermostat to the desired setting.
11. Turn on all electric power to the appliance.

12. If the appliance will not operate, follow the instructions under “To Turn Off Gas To The Appliance” and call your service technician or gas supplier.

### TO TURN OFF GAS TO THE APPLIANCE

1. Turn off all electric power to the appliance if service is to be performed.
2. Set the thermostat to the lowest setting.
3. Remove the front jacket panel.
4. Turn the gas control valve clockwise ↻ to “OFF”. The handle of the valve should be perpendicular to the pipe in the “OFF” position.
5. Replace the front jacket panel.

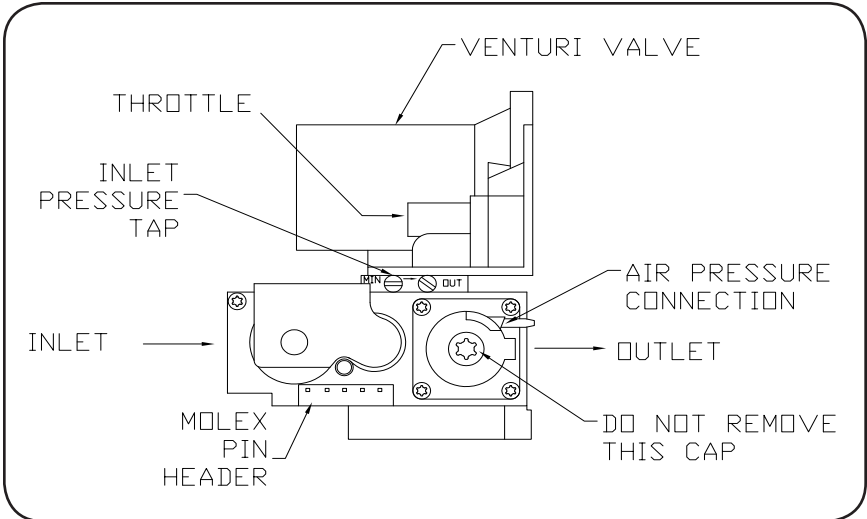

### BLOCKED FLUE/VENT SAFETY SHUTOFF

The Blocked Flue/Vent Safety Shutoff shuts off main burner gas in the event that the flow of combustion products through the flue ways is reduced. In the event of blocked flue ways, enough air will not be available to support combustion, and boiler control will lockout due to loss of proper air flow. If the boiler can not be restored to normal operating condition by resetting the control, contact a qualified service agency to check the flue ways and vent pipe for blockage.

## MAINTENANCE AND CLEANING

Regular service and maintenance by a qualified service agency must be performed at least once every 12 months (preferably at the start of each heating season) to assure safe, trouble free operation and maximum efficiency. **The boiler owner SHOULD NOT attempt these procedures.**

This annual service should include at a minimum:

- Examining the flue passages between boiler sections, burner, and condensate lines, and cleaning if necessary.
- Inspecting venting and air intake system and cleaning if necessary.
- Placing the boiler in operation and performing the checkout procedure.
- Inspecting the condensate drain pipe and cleaning if necessary.
- Checking all gasketed and threaded joints for leakage, and repairing if necessary.

Particular attention should be given to potential deterioration from corrosion or other sources. Detailed procedures can be found in Section XII, "*Maintenance and Cleaning*," of the Installation Manual (P/N# 240006103).

**The boiler owner SHOULD perform the following periodic maintenance procedures.**

DAILY DURING HEATING SEASON:

1. Check for and remove any obstruction to the flow of combustion air or venting of flue gases.
2. Check that boiler area is free from combustible materials, gasoline, and other flammable vapors and liquids.

## MAINTENANCE AND CLEANING

### MONTHLY DURING HEATING SEASON:

1. Remove jacket front and top panels and check for piping leaks around relief valve and other fittings. If found, contact a qualified service agency. **DO NOT USE STOP LEAK COMPOUNDS.**
2. Test relief valve. Refer to valve manufacturers instructions packaged with relief valve.
3. Visually inspect the venting and air intake system for proper operation. If the vent or air intake show any signs of deterioration or leakage, contact a qualified service agency to repair or replace them immediately and to insure proper reassembly and resealing of the system.
4. Visually inspect the PVC condensate drain pipe for proper operation. If the drain pipe shows any signs of blockage, leakage, or deterioration contact a qualified service agency to clean, repair, or replace it immediately.
5. Check air vent(s) for leakage.
6. Where low water cut offs are used, a periodic inspection of the low water cut off is necessary, including flushing of float type devices. Refer to low water cut off manufacturer's specific instructions.

### END OF EACH HEATING SEASON (ANNUAL SHUT DOWN PROCEDURE):

1. Turn off gas to boiler as described "*To Turn Off Gas To Appliance*" in Section V of the Control Manual and Operating Instructions (P/N# 240006104).
2. If the heating system is to remain out of service during freezing weather and does not contain antifreeze, drain system completely. If the boiler will be exposed to freezing temperatures, drain condensate lines. Otherwise, do not drain the system or boiler.

**IMPORTANT:** Should overheating occur or the gas supply fail to shut off, do not turn off or disconnect the electrical supply to the pump. Instead shut off the gas supply at a location external to the appliance.

