

ODV-B

GAS FIRED BOILERS
FOR FORCED HOT WATER

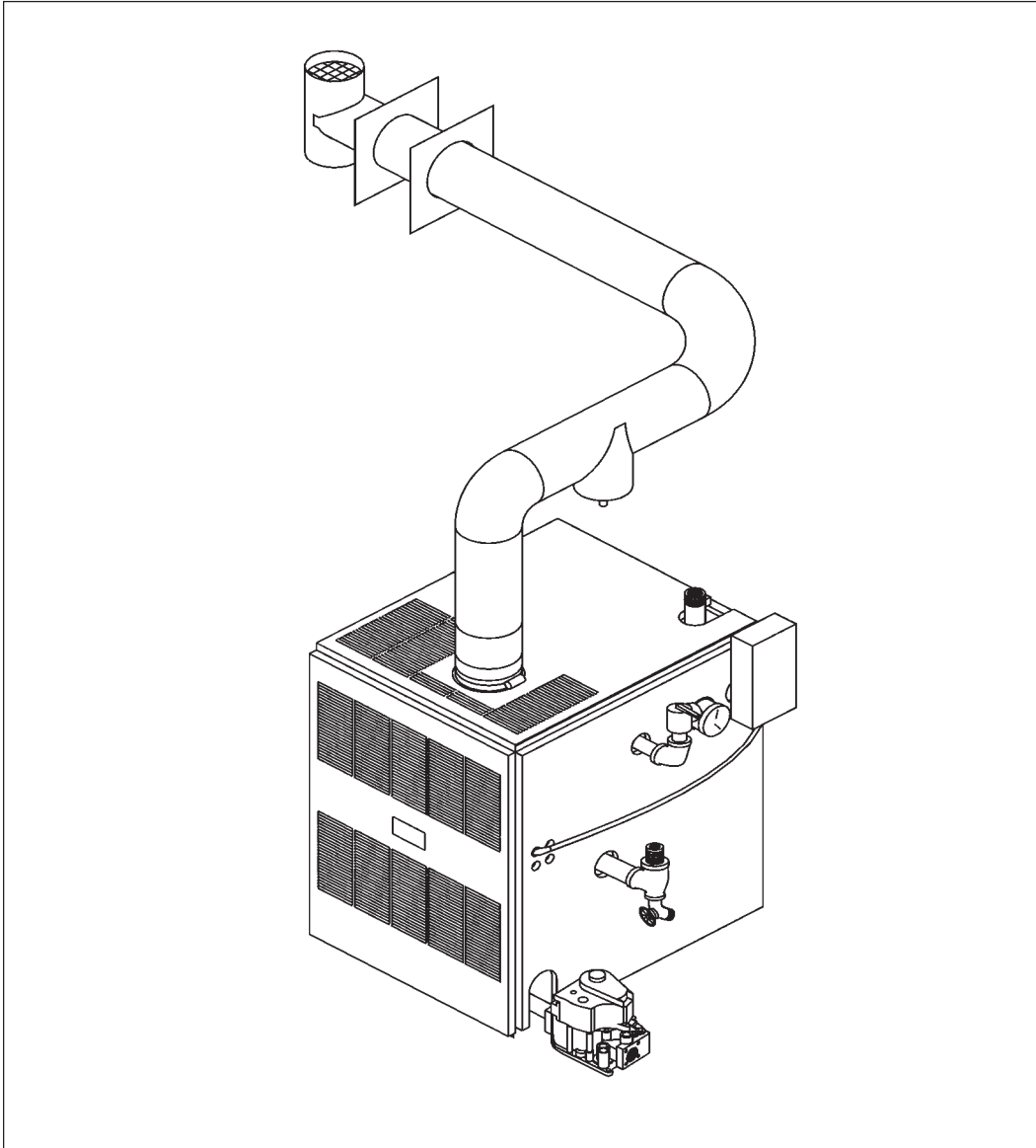

VENTING ADDENDUM

Olsen
Heating & Cooling Products

ECR International Ltd. - Olsen Division • P.O. Box 900 • Wallaceburg, Ont. N8A5E5

TABLE OF CONTENTS

| | |
|-------------------------------------|-------------|
| HORIZONTAL PIPING | PAGES 1-10 |
| WARNINGS | PAGE 1 |
| INSTALLATION | PAGES 2-3 |
| TYPICAL INSTALLATION | PAGE 4 |
| FLEX-L PIPING COMPONENTS | PAGE 5 |
| HEAT FAB PIPING COMPONENTS | PAGE 6 |
| Z-FLEX PIPING COMPONENTS | PAGE 7 |
| PROTECH PIPING COMPONENTS | PAGE 8 |
| CONDENSATE DRAINS | PAGE 9 |
| LOCATING THE VENT TERMINATION | PAGES 9-10 |
| | |
| VERTICAL VENT PIPING | PAGES 11-18 |
| INSTALLATION | PAGE 11-16 |
| B VENT SINGLE APPLIANCE | PAGE 16 |
| B VENT DUAL APPLIANCE | PAGE 17 |
| CATEGORY I VENT INSTALLATION | PAGE 18 |

HORIZONTAL VENT PIPE INSTALLATION INSTRUCTIONS (Through the wall)

THIS BOILER IS DESIGN CERTIFIED FOR USE WITH THE FOLLOWING VENTING SYSTEMS.

| | | | | |
|---------|-------------|----------|---------|-----------|
| COMPANY | HEAT-FAB® | FLEX-L® | Z-FLEX® | ProTech® |
| PRODUCT | SAF-T-VENT™ | STAR-34™ | Z-VENT™ | FasNSeal™ |

 **CAUTION:** THE ABOVE VENT PIPE AND FITTINGS ARE USED FOR VENTING GAS BURNING CATEGORY III AND IV APPLIANCES. DO NOT USE THIS VENT PIPE OR FITTINGS FOR VENTING APPLIANCES BURNING FUELS SUCH AS WOOD, OIL, KEROSENE OR COAL.

 **CAUTION:** DO NOT USE THIS VENT PIPE AND FITTINGS FOR VENTING INCINERATORS OF ANY KIND.

WARNINGS:

1. FOR CORRECT INSTALLATION OF VENT SYSTEM, READ ALL OF THESE INSTRUCTIONS AND REFER TO THE VENT PIPE MANUFACTURER'S INSTRUCTIONS.
2. FAILURE TO USE THIS VENTING SYSTEM WILL VOID THE MANUFACTURER'S WARRANTY AND MAY RESULT IN RAPID DETERIORATION OF THE VENTING SYSTEM, A POTENTIAL HEALTH HAZARD.
3. FAULTY VENT INSTALLATION CAN ALLOW TOXIC FUMES TO BE RELEASED INTO LIVING AREAS. THIS MAY CAUSE SERIOUS BODILY INJURY OR PROPERTY DAMAGE. VENT PERFORMANCE MAY ALSO BE AFFECTED BY IMPROPER ASSEMBLY.
4. INSTALL SEPARATE VENTS FOR FORCED EXHAUST APPLIANCES AND NATURAL DRAFT APPLIANCES. A COMMON VENT BETWEEN NATURAL DRAFT AND FORCED EXHAUST APPLIANCES MAY CAUSE TOXIC GASES TO EXHAUST THROUGH THE NATURAL DRAFT APPLIANCE RATHER THAN TO OUTSIDE AIR. BREATHING EXHAUST GASES WILL CAUSE SERIOUS PERSONAL INJURY OR DEATH.

 **WARNING:** ALL INSTALLATIONS OF BOILERS AND VENTING SHOULD BE DONE ONLY BY A QUALIFIED EXPERT AND IN ACCORDANCE WITH THE APPROPRIATE OLSEN MANUAL. INSTALLING OR VENTING A BOILER OR ANY OTHER GAS APPLIANCE WITH IMPROPER METHODS OR MATERIALS MAY RESULT IN SERIOUS INJURY OR DEATH DUE TO FIRE OR TO ASPHYXIATION FROM POISONOUS GASES SUCH AS CARBON MONOXIDE WHICH IS ODORLESS AND INVISIBLE.

HORIZONTAL VENT INSTALLATION:

A. The boilers covered in this section are design-certified as CATEGORY 3 for venting, only when they are installed with manufacturer specified vent system components and installation practices.

B. Install vent pipe beginning at the vent connector and work toward the vent cap.

C. Vent pipe and fittings **MUST NOT** be routed into, through, or within any other vent, such as an existing masonry chimney or factory built chimney. (Recommended installation is shown in figure 1 page 3, unacceptable installation is shown in figure 2 page 3).

D. Vent pipe lengths. The maximum length is the combined length of straight horizontal and vertical runs, and the equivalent straight length of fittings. The required lengths for each boiler are as follows:

VENT PIPE LENGTHS

| Model | Vent Pipe Dia. | VENT LENGTHS | | EQUIV. feet per fitting |
|------------|----------------|--|-----------------|-------------------------|
| | | Maximum | Minimum | |
| ODV50/100 | 3" | 30' W/ Condensate Tee & 2 Elbows | 2' W/1 Elbow | 5' |
| ODV125 | 3" | 25' W/1 Elbow | 2' W/1 Elbow | 5' |
| ODV150/200 | 4" | 30' W/1 Elbow | 2' W/1 Elbow | 5' |

Example: 20 feet of vent pipe w/1 elbow is Equivalent to 15 feet of vent pipe w/2 elbows. Note, condensate trap is not required on models ODV150 thru 200.

E. The vent pipe should slope upward from the boiler at least 1 inch for every 4 feet.

F. No portion of the vent pipe should have dips or sags where condensate could collect, see figure 3 on page 3 for a typical vent system.

G. Rigidly support vent pipe every 5 feet and at the elbows. Plumbers straps may be used.

H. Clearances and enclosures. ALL vent pipe and fittings must be installed with appropriate air space clearances to combustibles. These air space clearances apply to indoor or outdoor vents, whether they are open, enclosed, horizontal or vertical or pass through floors, walls, roofs, or framed spaces. The appropriate air space clearances should be observed to joists, studs, subfloors, plywood, drywall, or plaster enclosures, insulated sheathing, rafters, roofing, and any other combustible material. The minimum air space clearance also applies to electrical wires and any kind of building insulation.

 **WARNING:** DO NOT INSULATE OR OTHERWISE WRAP VENT PIPE OR FITTINGS.

For Horizontal runs maintain a minimum air space clearance of 6 inches for 3 inch and 4 inch vent pipe to any combustible material, electric wires, and building materials.

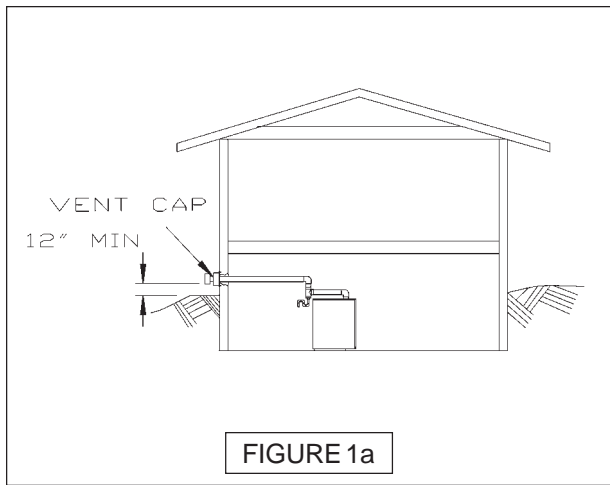

FIGURE 1a

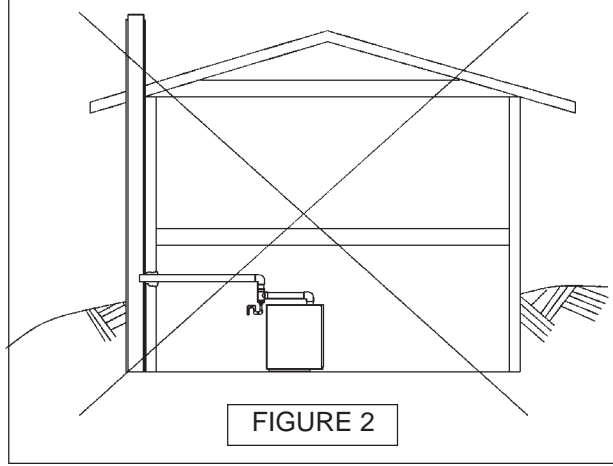
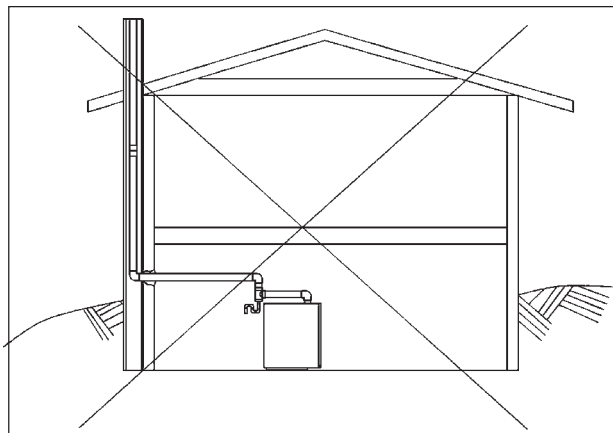

FIGURE 2

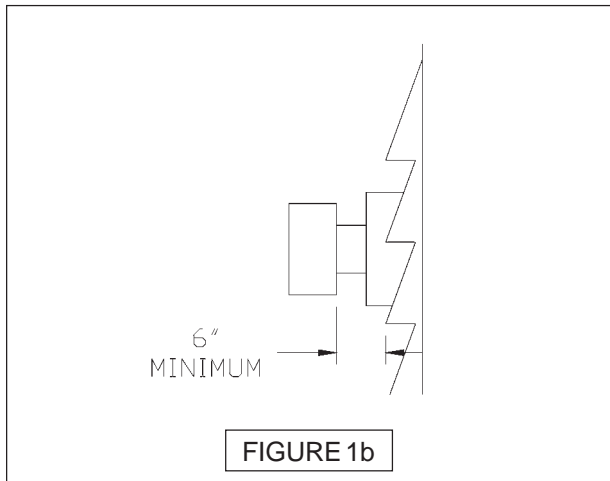

FIGURE 1b

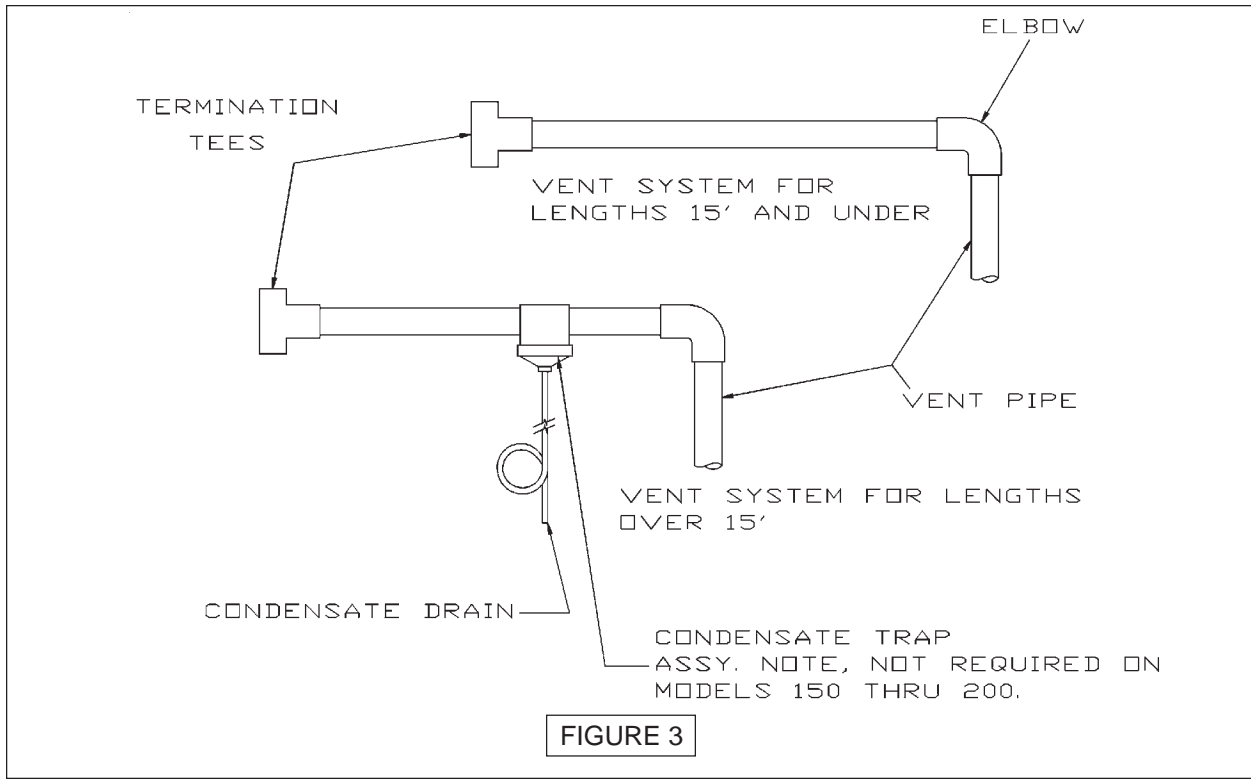
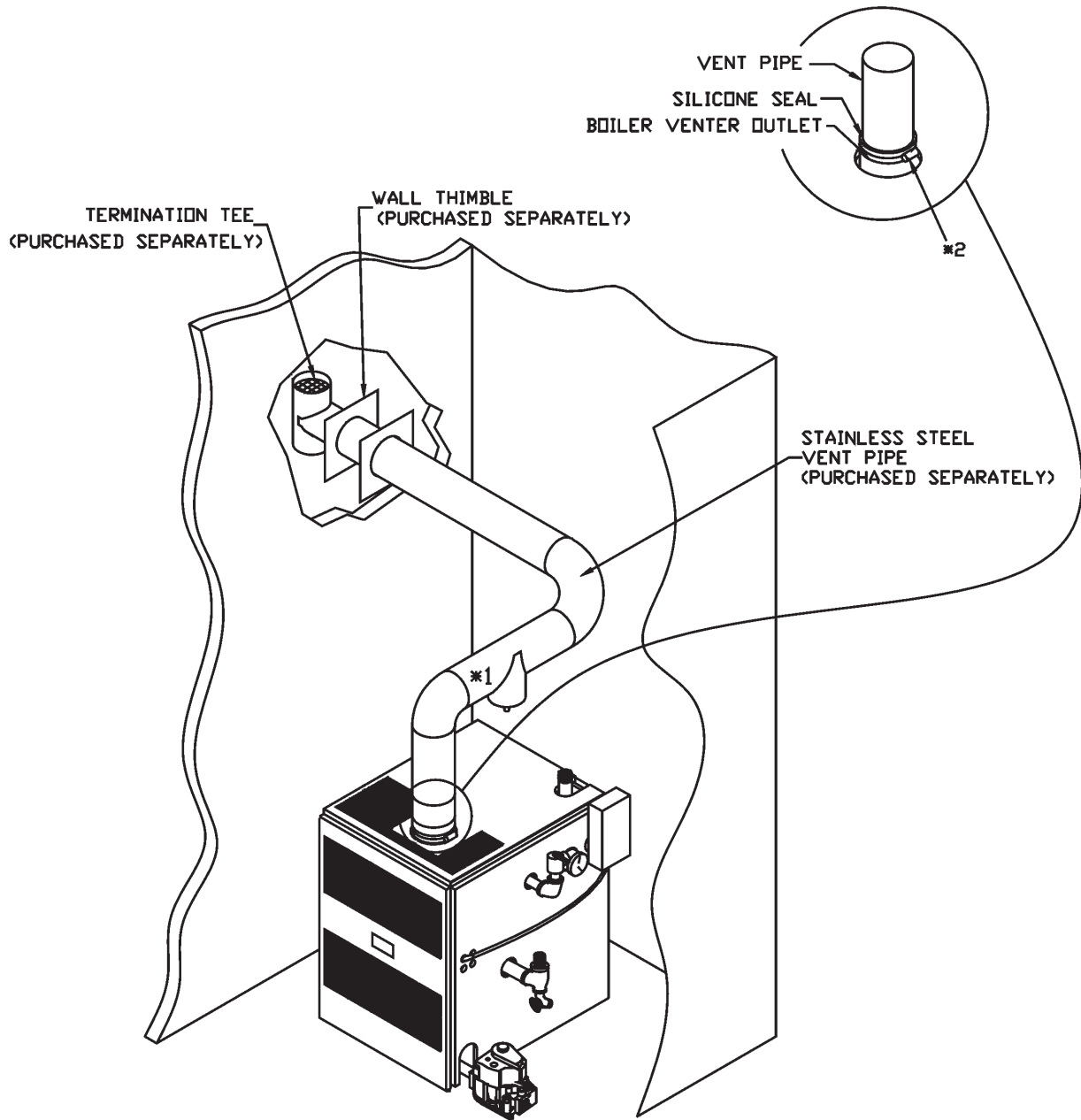

FIGURE 3

TYPICAL INSTALLATION



Notes:

***1 : A condensate tee/drain is only needed when horizontal vent lengths exceed 10 feet.**

***2 : Insert vent pipe in boiler venter outlet (vent adapter), apply silicone completely around edge of outlet and tighten clamp.**

FIGURE 4

PAGE 4

Flex-L® Star-34™ Vent Pipe Components

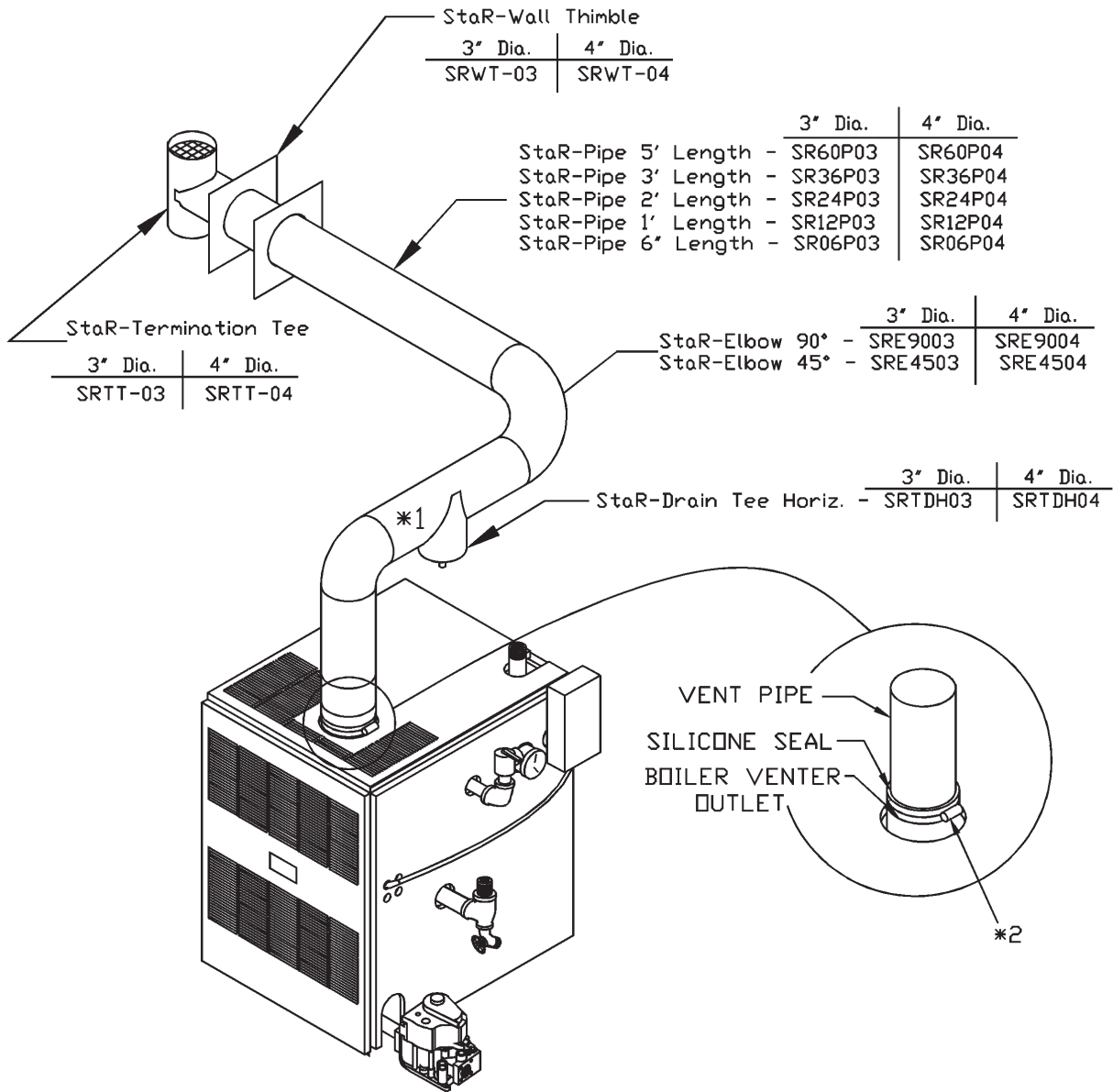

Notes:

***1 : A condensate tee/drain is only needed when horizontal vent lengths exceed 10 feet.**

***2 : Insert vent pipe in boiler venter outlet (vent adapter), apply silicone completely around edge of outlet and tighten clamp.**

FIGURE 5

Heat Fab® Saf-T Vent™ Vent Pipe Components

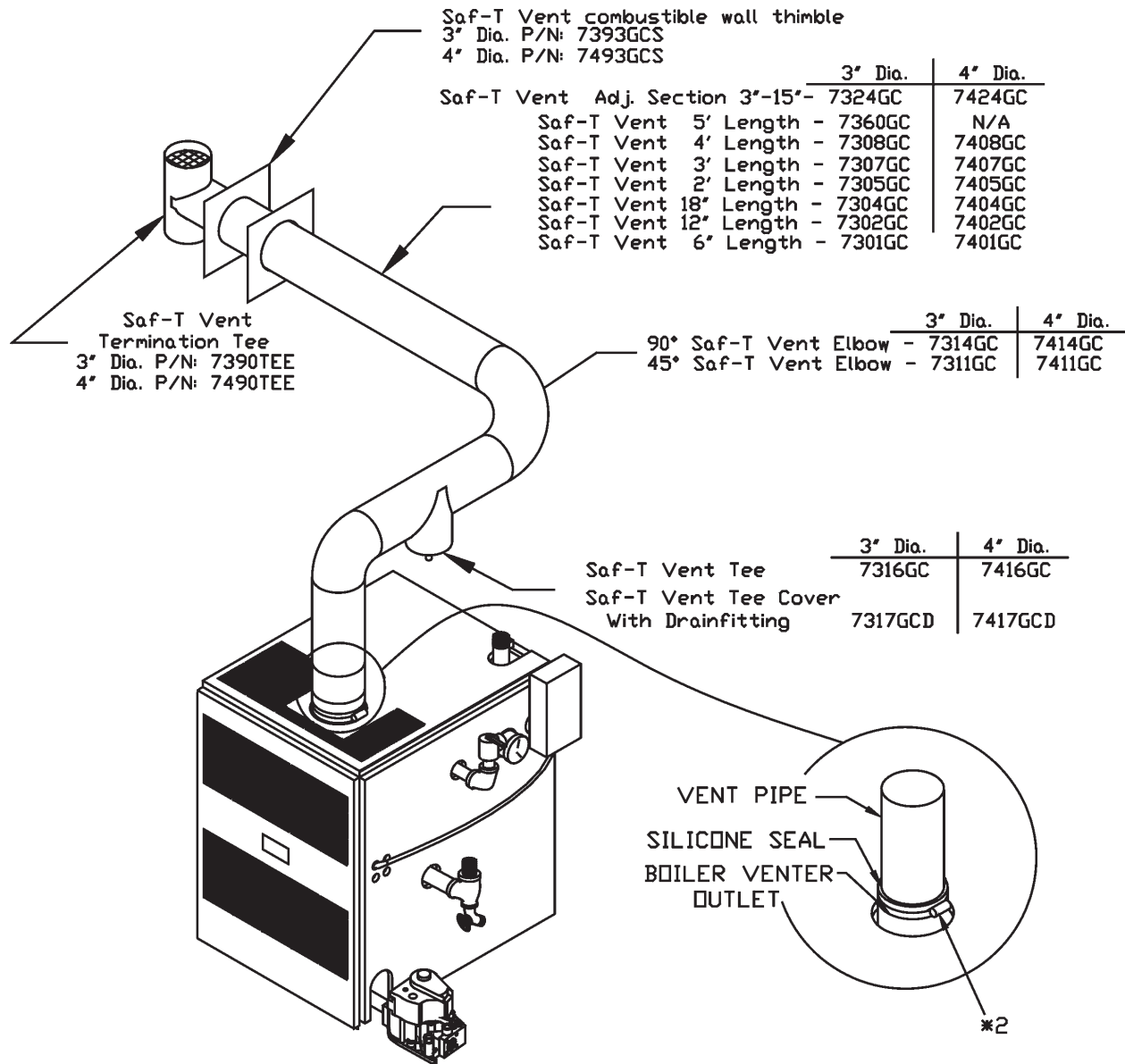

Notes:

*1 : A condensate tee/drain is only needed when horizontal vent lengths exceed 10 feet.

*2 : Insert vent pipe in boiler venter outlet (vent adapter), apply silicone completely around edge of outlet and tighten clamp.

FIGURE 6

PAGE 6

Z-Flex® Z-Vent™ Vent Pipe Components

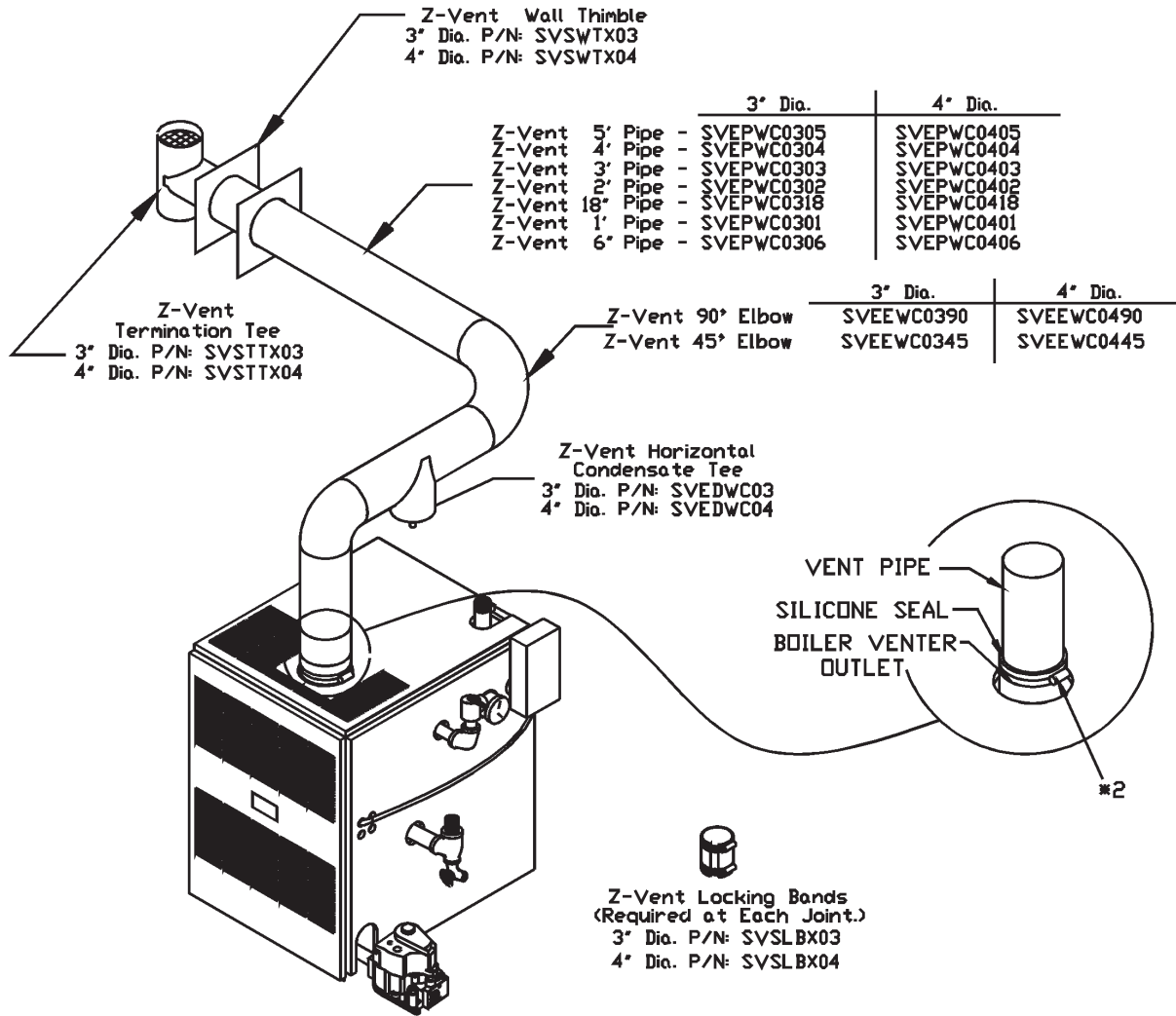

Notes:

***1 :** A condensate tee/drain is only needed when horizontal vent lengths exceed 10 feet.

***2 :** Insert vent pipe in boiler venter outlet (vent adapter), apply silicone completely around edge of outlet and tighten clamp.

FIGURE 7

ProTech® FasNSeal™ Vent Pipe Components

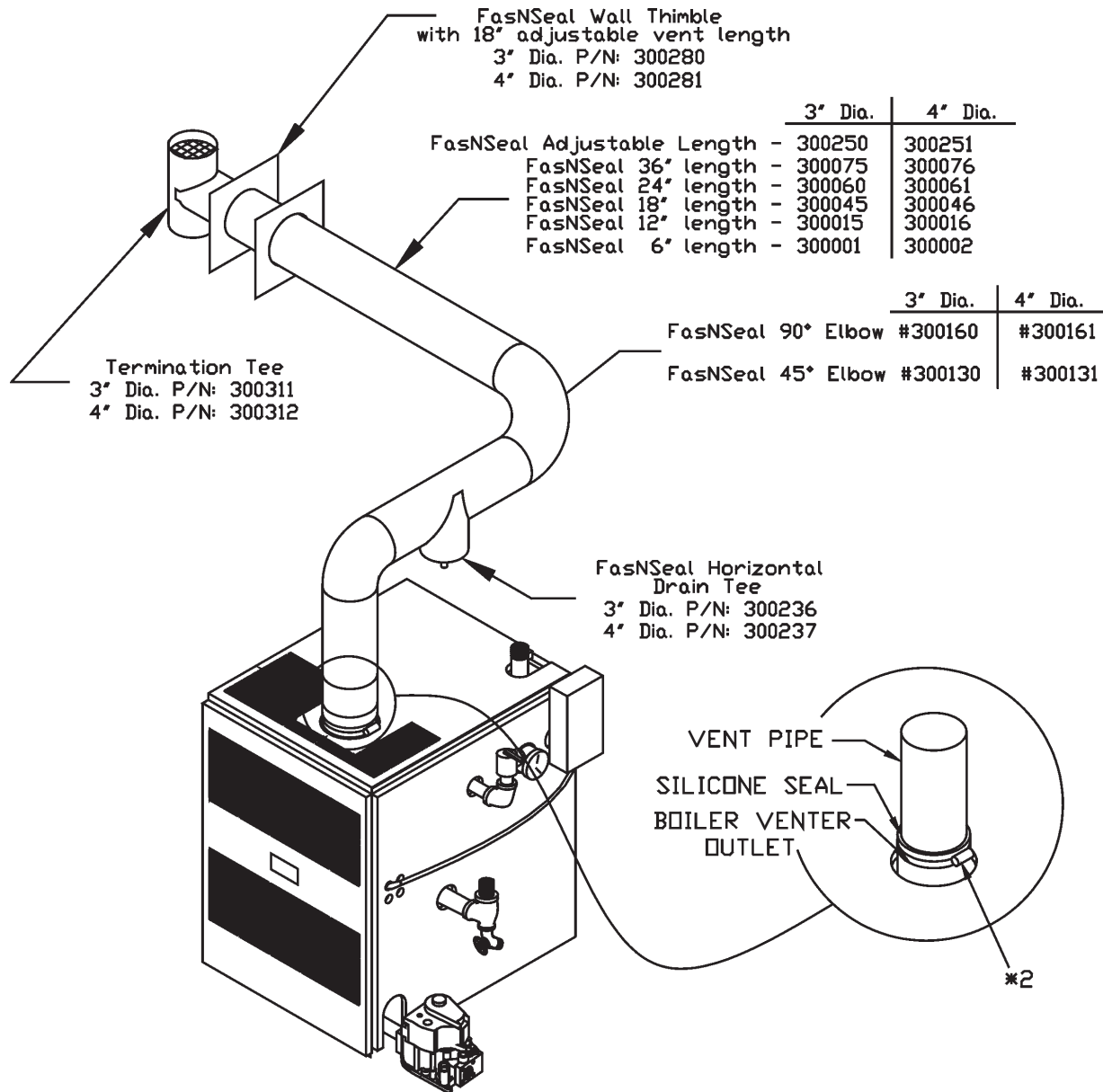

Notes:

*1 : A condensate tee/drain is only needed when horizontal vent lengths exceed 10 feet.

*2 : Insert vent pipe in boiler venter outlet (vent adapter), apply silicone completely around edge of outlet and tighten clamp.

CONDENSATE DRAINS

(Note: A condensate drain is not required on models ODV150 thru 200)



WARNING: DO NOT PLACE CONDENSATE DRAIN WHERE FREEZING MAY OCCUR.

CONDENSATE DRAINS ARE REQUIRED IN THE VENT WHEN USING THE CONDENSATE TEE. THE CONDENSATE DRAIN FITTING MUST BE PLUMBED TO A SANITARY DRAIN FOR LIQUID CONDENSATE DISPOSAL.

Refer to figure 9 below for the following instructions.

Condensate drain is plumbed with 3/8" (1 cm) inside diameter flexible tubing. Refer to "GENERAL INSTRUCTION FOR SEASONAL STARTUP AND MAINTENANCE", in the Installation Manual for maintenance recommendations and schedule.

1. Flexible Tubing Condensate Drain.

In the vent, and close to the appliance, install a tee with a run outlet. Install condensate drain in the down outlet with high temperature adhesive. Connect the condensate drain outlet to commercially available flexible tubing (minimum length 40"). Below the drain outlet, make a 6" diameter loop in 3/8" ID tubing, or a 9" diameter loop in 5/8" ID tubing. Secure the loop with a plastic cable tie. Run the other end of the flexible tubing to a sanitary drain. (Use a condensate pump if necessary)

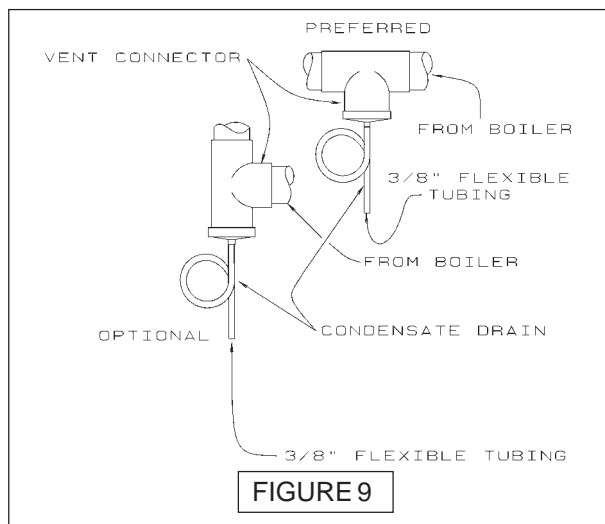

LOCATING THE VENT TERMINATION

- A. At least 12 inches above finished grade, or at least 12 inches above the normally expected snow accumulation level in geographical areas where snow accumulates.
- B. 4 feet away from and not above any doors or windows.
- C. At least 3 feet above any forced air inlet located within 6 feet horizontally.
- D. At least 6 feet from a combustion air intake of another appliance.
- E. At least 4 feet horizontally from electric meters, gas meters, regulators and relief equipment.
- F. Do not locate the vent termination in traffic areas like walkways, unless it is at least 7 feet above finished grade.
- G. Do not locate the vent termination too close to shrubbery as flue products may stunt or kill them.
- H. Some building materials may be affected by flue products expelled near unprotected surfaces. Sealing or shielding of exposed surfaces with a corrosion resistant material (such as aluminum sheet) may be required to prevent staining or deterioration.
- I. When installing vent cap secure it to a noncombustible wall or a combustible wall thimble. Refer to vent pipe manufacturers instructions.
- J. See the latest revision of the NFGC, ANSI Z223.1. When installed in Canada: The latest revision of the CAN/CSA - B149 Natural Gas and Propane Installation Code.

NOTE: IF THERE IS A POTENTIAL FOR EXCESSIVE WINDS, SPECIAL CONSIDERATION SHOULD BE GIVEN TO LOCATE THE VENT TERMINATION AWAY FROM THE WINDWARD SIDE OF THE BUILDING.

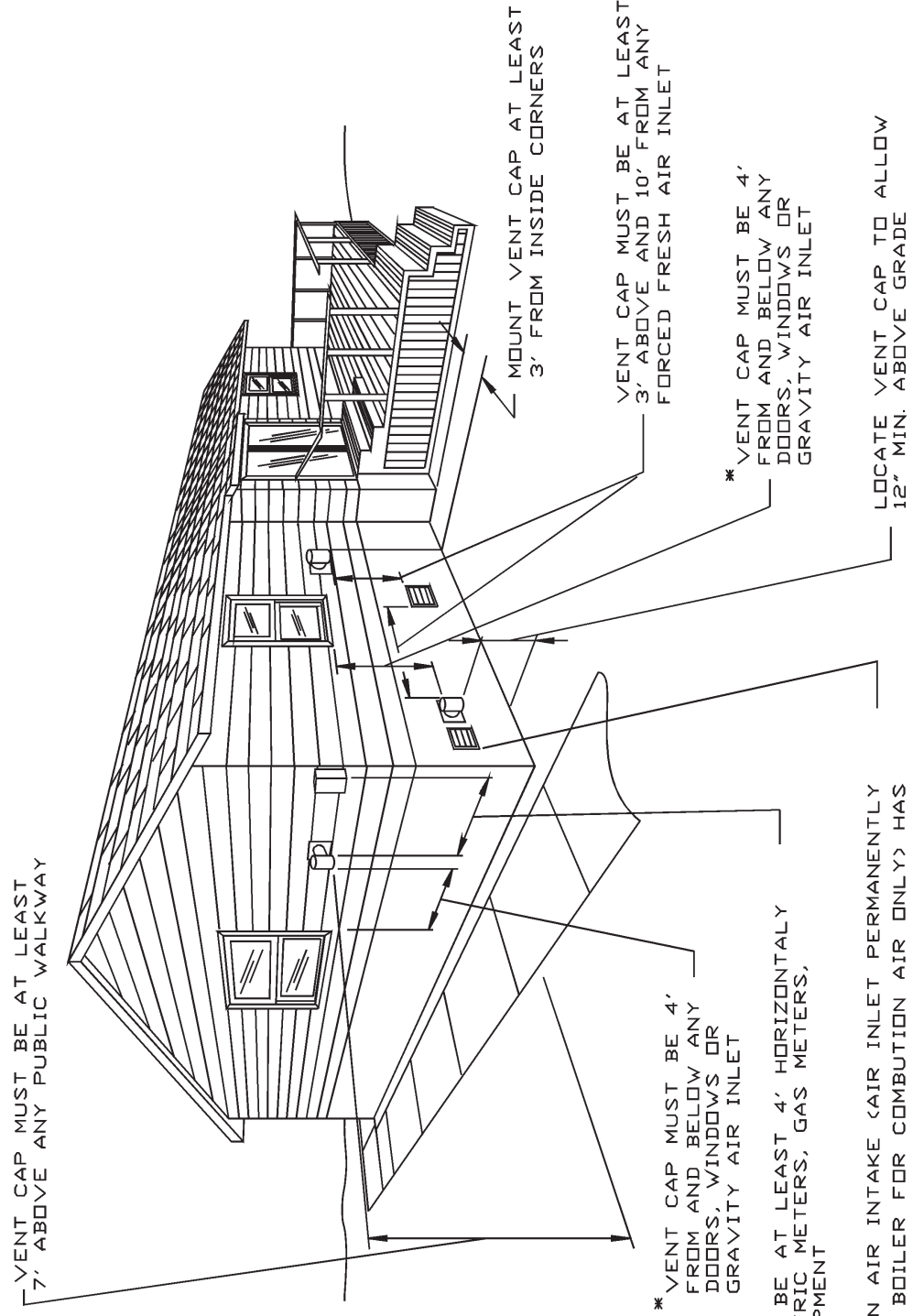

FIGURE 10

DIRECT COMBUSTION AIR INTAKE (AIR INLET PERMANENTLY FASTENED TO THE BOILER FOR COMBUSTION AIR ONLY) HAS NO DISTANCE REQUIREMENT

VERTICAL VENT PIPE INSTALLATION INSTRUCTIONS

(PROVIDING FOR PROPER VENTING THROUGH THE ROOF)

Vent boiler making reference to the latest revision of NFGC, ANSI Z223-1 (when installed in Canada: refer to the CAN/CSA - B149 Natural Gas and Propane Installation Code) using these instructions and the requirements of the local utilities and other local code authorities. You must connect boiler to a vent or factory-built chimney. Vent or factory-built chimney must meet a recognized standard. Chimney lining method and material must comply with local code requirements. Use corrosion-resistant material meeting nationally recognized standards for vent construction.



WARNING: Inadequate vent or chimney could allow combustion products to collect in structure, resulting in injury or death.



WARNING: Vent this boiler separately from any appliance designed to burn solid fuel, particularly wood burning or coal burning appliances. Improper venting could allow combustion products to collect in the structure, resulting in injury or death.

A. VENTING CATEGORY

The boilers covered by this manual are design-certified as CATEGORY 1 for venting. CATEGORY 1 Appliances have non-positive vent static pressure and rely on the heat content of combustion products to vent. You may common vent CATEGORY 1 boilers.

The boilers covered by this manual are also design certified as CATEGORY 3 for venting, only when they installed with manufacturer specified vent system components and installed practices.(Ref. pages 1-10 for category 3 venting instructions)

B. DESIGN CONSIDERATIONS

1. Avoid oversizing boiler for your application. Select a boiler model with a rated heating output close to the calculated heating load. This extends the firing period, decreasing the potential for condensate formation in the vent.

2. Too small a vent cannot carry all combustion products outdoors. Too large a vent will not vent combustion products rapidly enough to avoid potential for condensation. Refer to pages 15 thru 18 for correct vent size.

3. Vent height must be a minimum of six feet. Minimize vent connector horizontal runs to the extent possible for best performance.

4. The designer must consider the building's orientation, answering these questions.
(Ref. pages 13-15)

A. Will the vent terminate outside the building where its operation could be adversely affected by winds?

B. Could any adjacent buildings adversely affect vent operation?

C. Allowing for these factors can reduce the possibility of downdraft conditions.

5. If your local experience indicates possible condensation problems, provide for draining and disposal of venting system condensate.

C. VENT SIZING

1. Sometimes the horizontal distance from the boiler to the vent or chimney is already

given; this is known as the horizontal vent connector run. The vent or chimney height is also usually given as the Btuh input of the gas appliances served by the vent.

Check these parameters to be sure the venting system will work. Use approved engineering practices and part 7 & 10 of the latest revision of the (NFGC) National Fuel Gas Code, ANSI Z223.1/NFPA54. When installed in Canada: The latest revision of the CAN/CSA - B149 Natural Gas and Propane Installation Code.

2. Use this venting addendum for single appliance venting and multiple appliance (common) venting. For multistory installations, refer to the latest revision of the National Fuel Gas Code ANSI Z223.1/NFPA54. When installed in Canada: The latest revision of the CAN/CSA - B149 Natural Gas and Propane Installation Code.

D. VENT CONNECTOR

1. Vent connectors must be made of noncombustible, corrosion resistant material capable of withstanding vent gas temperatures. They must be thick enough to withstand physical damage and be accessible for inspection, cleaning and replacement.

2. Use Type B 1 vent connector in or through attics, crawl spaces, or other cold areas. Install thimbles that meet local codes when vent connectors pass through walls or partitions of combustible material.

3. Keep vent connectors as short as possible by locating boiler as close as practical to vent or chimney. Avoid unnecessary turns or bends which create resistance to flow of vent gases. Adding an elbow adds resistance. For example, adding a 6" 90-degree elbow would be the equivalent of adding 20 feet of horizontal 6" pipe. (45-degree elbows have lower resistance than 90-degree elbows, and can work for most vent runs).

4. If you join two or more vent connectors before they enter the vertical vent or chimney, see figure 17, on page 17. Also refer to NFGC book, ANSI standards and NFPA book. In Canada refer to the CAN/CSA - B149 Natural Gas and Propane Installation Code.

5. Do not connect this boiler to any portion of a vent system which operates under positive pressure. Positive pressure will result with CATEGORY 3 or 4 appliances that are connected to the vent.

6. Do not connect vent connector to a chimney flue serving a fireplace.

E. VERTICAL VENT OR CHIMNEY

1. Vents and chimneys usually extend vertically with offsets not exceeding 45-degrees. Consider vent pipe runs more than 45-degrees as horizontal runs. Include their length in the total horizontal run.

2. Designer and installer must provide an appropriately sized common vent for all appliances connected to it (Ref. to figure 17, on page 17 or the latest revision of the NFGC, ANSI Z223.1. When installed in Canada: The latest revision of the CAN/CSA - B149 Natural Gas and Propane Installation Code).

3. Connect this CATEGORY 1 boiler only to vent systems with other CATEGORY 1 appliances.

! WARNING: Do not connect this CATEGORY 1 boiler to a vent system used by a CATEGORY 3 and 4 appliance. Do not connect it to vents with mechanical draft systems operating at positive pressure. Improper venting could allow combustion products to collect in the structure during use, resulting in damage, injury or death.

F. CHIMNEY LINING

Use a suitably sized Type B1 vent liner or suitable corrugated liner. (See Figure 11 below)

! WARNING: Support vent liner in a masonry chimney. Maintain at least 1" clearance on all sides to reduce the possibility of condensate in vent. Condensate may cause vent to deteriorate allowing combustion products to collect in structure, which could result in injury or death. See Figure 12 below.

! WARNING: Vent liner must not block opening where other appliance's vent connectors enter chimney. Blocked openings will cause combustion products to collect in the structure, resulting in damage, injury or death.

! WARNING: Do not use unlined masonry chimneys. These increase risk of condensate formation, which may cause chimney to deteriorate, allowing combustion products to collect in the structure, resulting in damage, injury or death.

G. VENT TERMINATION

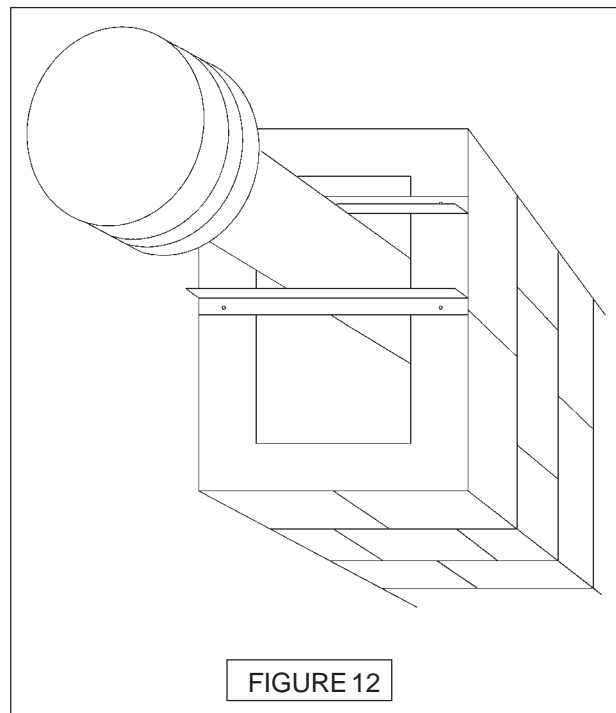
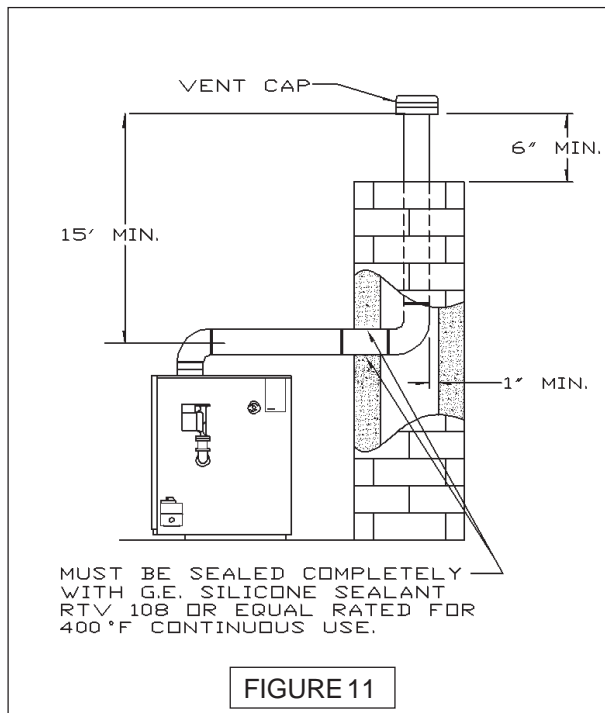

1. Terminate all vertical vents with a listed vent cap or roof assembly unless local codes require otherwise. See vent cap or roof assembly manufacturer's instructions. Locate vent termination (vent cap or roof assembly) in an area without positive pressures or eddy currents. Eddy currents occur when air swirls over roof peaks. They cause down-drafts and adversely affect vent operation. See Figure 13 at right. Some vent terminations or caps protect against eddy currents and down-drafts. Consult their manufacturer's instructions. Vent terminations or caps should usually be at least the same size as the vent. They may be larger if the installation warrants.

2. Vent systems must end at least five feet above the highest gas appliance connection. The vent pipe must extend at least three feet above the point where it passes through the roof. Vent termination must be at least two feet higher than any portion of building within ten feet horizontal and vent termination must be at least two feet higher than roof peaks within ten feet horizontal.

See figures 14 and 15 below. Some vent cap manufacturers offer vent caps that allow reduced clearances. Consult their instructions.

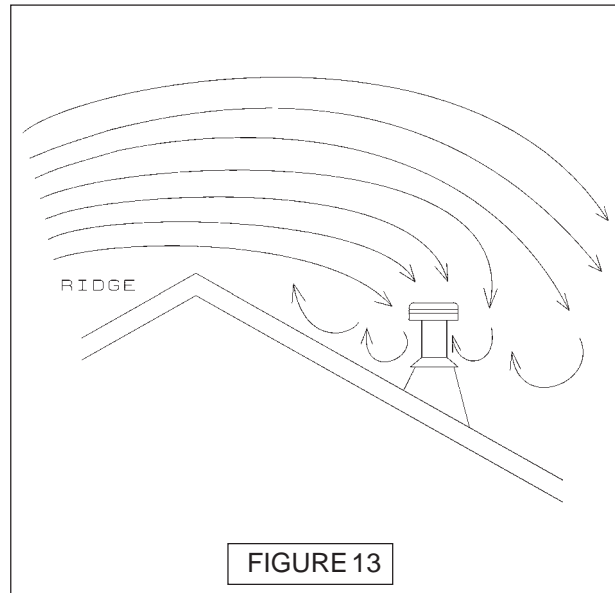
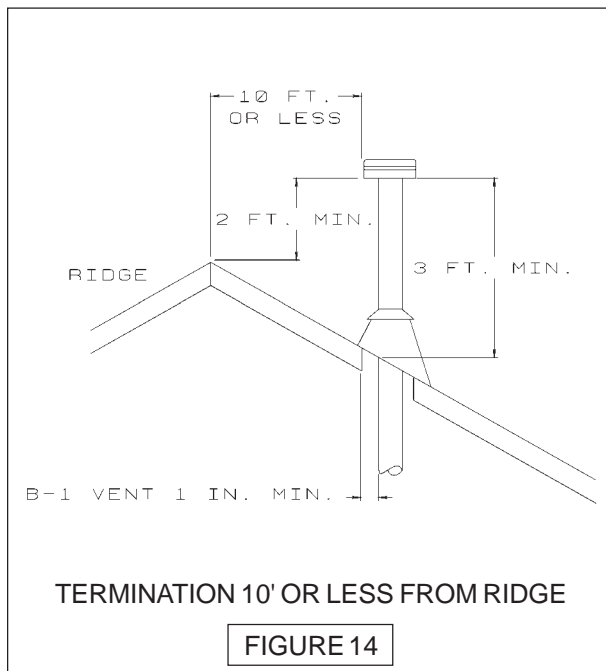

FIGURE 13

! WARNING: Failure to properly terminate vent chimney systems could allow combustion products to collect in the structure, resulting in injury or death.

3. Terminate venting system at least three feet above any forced-air building inlet within ten feet. Consider doors, windows and gravity air building inlets. Locate vent termination at least four feet below, four horizontal feet from or one foot above any of these openings.



TERMINATION 10' OR LESS FROM RIDGE

FIGURE 14

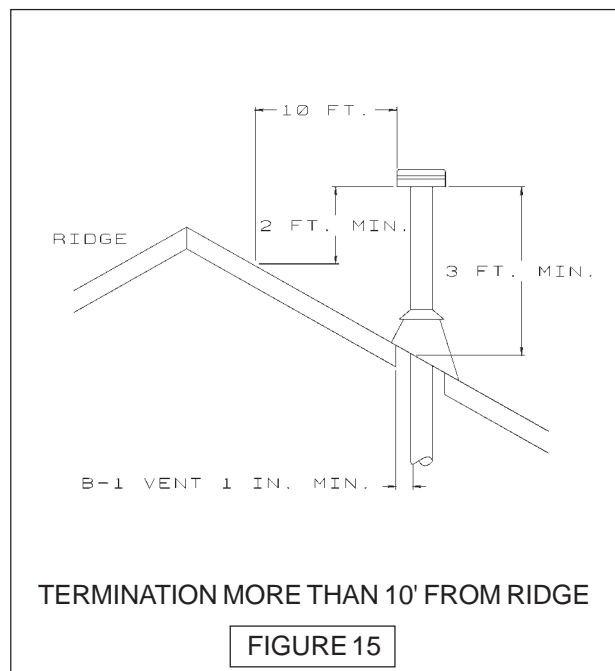

TERMINATION MORE THAN 10' FROM RIDGE

FIGURE 15

| ROOF PITCH | HEIGHT ABOVE ROOF | |
|---------------------|-------------------|--------------------------------------|
| FLAT TO 7/12 | 1.0 FT. | |
| OVER 7/12 TO 8/12 | 1.5 FT. | |
| OVER 8/12 TO 9/12 | 2.0 FT. | |
| OVER 9/12 TO 10/12 | 2.5 FT. |] BRACE TO ROOF AT TOP |
| OVER 10/12 TO 11/12 | 3.3 FT. | |
| OVER 11/12 TO 12/12 | 4.0 FT. |] BRACE TO ROOF AT TOP AND MID POINT |
| OVER 12/12 TO 14/12 | 5.0 FT. | |
| OVER 14/12 TO 16/12 | 6.0 FT. | |
| OVER 16/12 TO 18/12 | 7.0 FT. | |
| OVER 18/12 TO 20/12 | 7.5 FT. | |
| OVER 20/12 TO 21/12 | 8.0 FT. | |

ROOF PITCH CHART

H. INSTALLATION

1. Vent Adaptor.

Attach vent adaptor at draft inducer collar. See figure 18 on page 18. Use Kit # 56111101 for ODV 50-125 and Kit # 56111102 for ODV 150-200, or equivalent.



WARNING: Make sure that all vent pipe and connectors are secured because unsecured vent pipe connections may loosen. This can allow combustion products to collect in the structure, resulting in injury or death.

2. Vent Connector.

Install vent connectors without any dips or sags. Slope them upward from boiler at least 1/4" per foot. To prevent sagging, at each joint support vent connectors and horizontal portions using hangers, straps or equivalent. Seal all connections where vent connectors enter chimney. See Figure 11 on page 13.

3. Vertical Vent

Install vent materials following their listing terms, manufacturer's instructions, these instructions and local codes. A gas vent passing through a roof must extend through roof flashing, jack or thimble. It must terminate above the roof surface. (Ref. Figure 14 & 15)

I. EXISTING VENT CONSIDERATIONS

MASONRY CHIMNEYS PREVIOUSLY USED FOR VENTING EQUIPMENT SHOULD BE SUITABLY PER NFGC STANDARD. Also provide an accessible clean out per the latest revision of the NFGC, ANSI Z223.1, AND NFPA 54.1. When installed in Canada: The latest revision of the CAN/CSA - B149 Natural Gas and Propane Installation Code.

1. INSPECTION OF VENTS

A. Make sure existing vent or chimney is the proper size and construction for appliances that will use it. The best way to do this is to size as if it were a new installation. Compare the existing vent to your calculations and make necessary corrections.

B. Examine vent or chimney cleanouts to make sure they remain tightly closed when not in use. Make sure vent or chimney passageway is clear and free of obstructions. Look for evidence of condensate or deterioration in vent or chimney. Either of these means an inadequate vent.

C. If you find an inadequate vent or chimney, do not leave it as is. Repair or replace it. A new vent must meet these instructions and the latest revision of the National Fuel Gas Code ANSI Z223.1/NFPA54. In Canada CAN/CSA - B149.

VERTICAL VENTING INSTALLATION FOR (TYPE B VENT)*

| MODEL | D1 | D2 MIN | D2 MAX |
|--------------|----|-----------|-----------|
| ODV50 | 4" | 4" | 5" |
| ODV75 & 100 | 4" | 4" | 6" |
| ODV125 | 4" | 4" | 8" |
| ODV150 - 200 | 4" | 5" | 8" |

NOTE: See below*

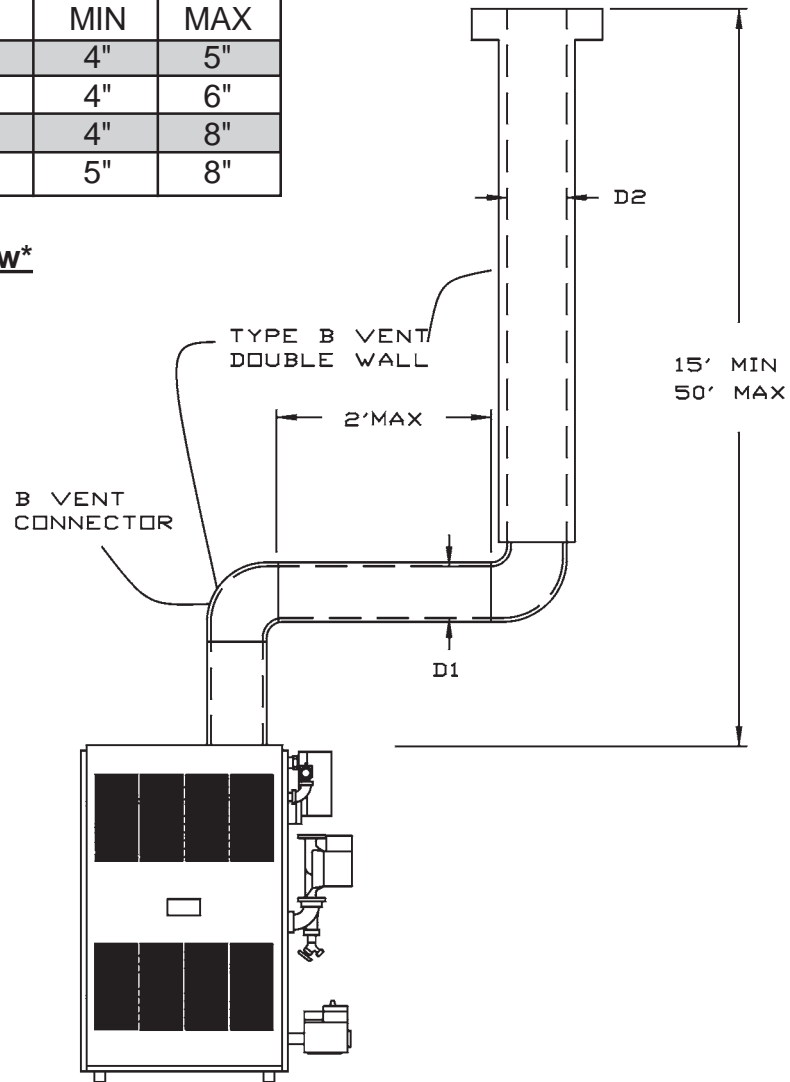

* The information contained in this figure is only one of many possible vertical venting configurations. Follow appropriate sections of NFGC for proper venting practice for category 1 appliances.

FIGURE 16

VERTICAL VENTING INSTALLATION FOR (TYPE B VENT) W/ NATURAL DRAFT WATER HEATER (40,000 BTU/HR)*

| MODEL | D1 | D2 MIN | D2 MAX |
|--------------|----|-----------|-----------|
| ODV50 | 4" | 4" | 4" |
| ODV75 & 100 | 4" | 5" | 6" |
| ODV125 & 150 | 4" | 6" | 8" |
| ODV175 & 200 | 4" | 7" | 8" |

NOTE: See below*

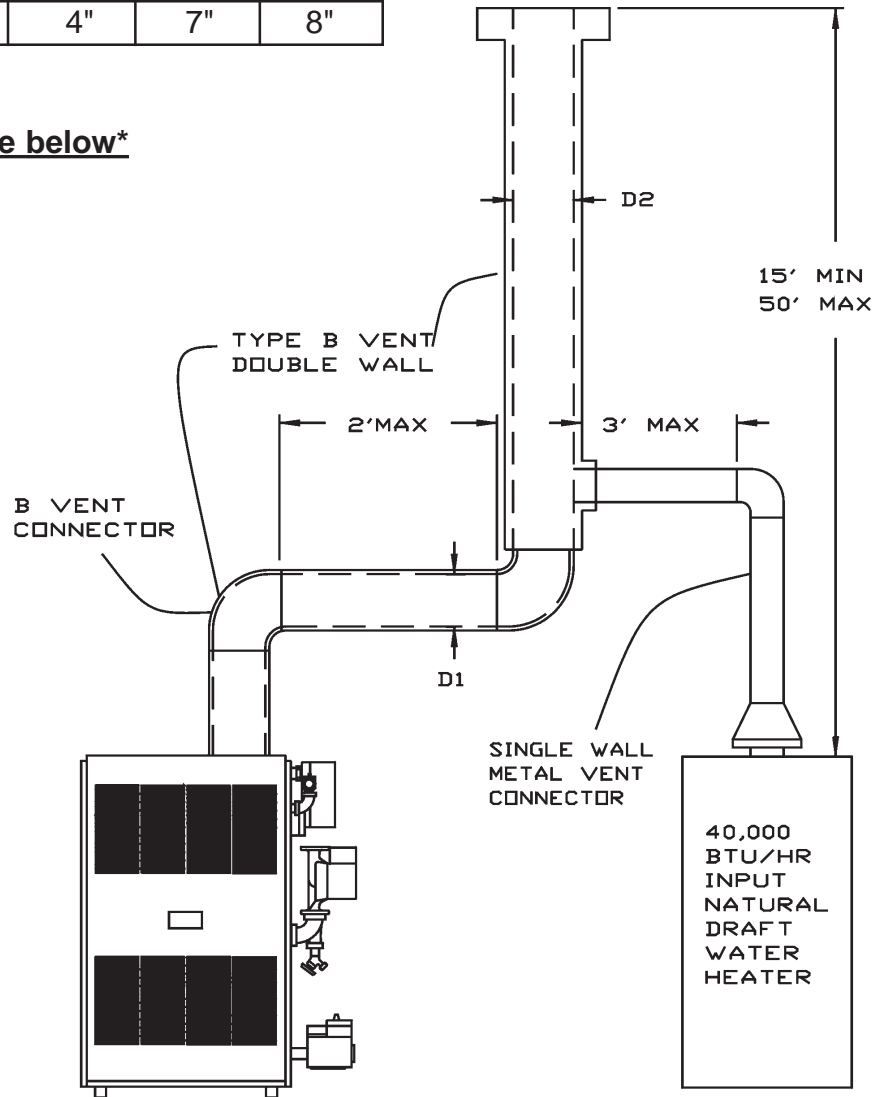

* The information contained in this figure is only one of many possible vertical venting configurations. Follow appropriate sections of NFGC for proper venting practice for category 1 appliances.

FIGURE 17

CATEGORY I VENT
 INSTALLATION
 USING
 HART & COOLEY
 TYPE B GAS VENT
 OR EQUIVALENT

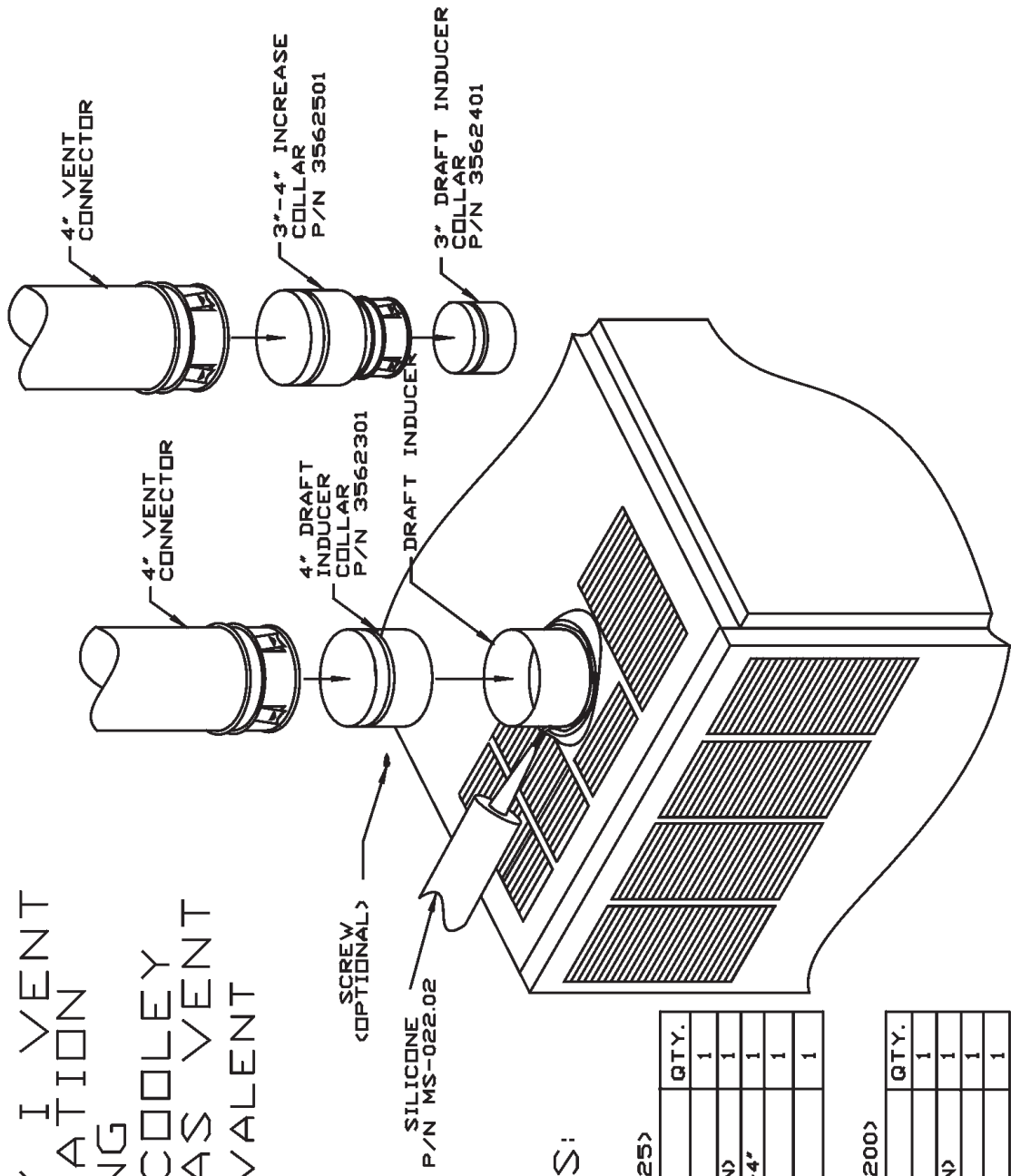

FIGURE 18

KIT CONTENTS:

KIT # 56111101
 <MODEL NUMBERS 50 THRU 125>

| PART NO. | DESCRIPTION | QTY. |
|-----------|---------------------|------|
| MS-022.02 | SILICONE | 1 |
| PK-022.01 | CARTON (NOT SHOWN) | 1 |
| 3562501 | VENT INCREASE 3"-4" | 1 |
| 3652401 | INDUCER COLLAR 3" | 1 |
| 37613301 | INSTRUCTIONS | 1 |

KIT # 56111102
 <MODEL NUMBERS 150 THRU 200>

| PART NO. | DESCRIPTION | QTY. |
|-----------|--------------------|------|
| MS-022.02 | SILICONE | 1 |
| PK-022.01 | CARTON (NOT SHOWN) | 1 |
| 3652301 | INDUCER COLLAR 4" | 1 |
| 37613301 | INSTRUCTIONS | 1 |